

The power to exceed



NorthStar marine batteries excel at providing high vibration resistance, with the high cranking amps and reserve capacity that watercraft demand.

- Pure lead AGM technology delivers exceptional CCA ratings and reserve capacity cycling ability
- Quick starting every time
- Cycles over 900 times to 50% depth of discharge
- Faster recharge than conventional batteries
- Proudly made in the USA at our state-of-the-art battery plant
- OEM fit is ensured - built to exact BCI standards
- Housed in advanced plastics for durability performance and heat resistance
- Advanced AGM construction means no water levels to check or terminals to clean
- Approved as non-hazardous cargo for ground sea and air transport DOT 49CFR173.159(d), (i) and (ii)

# NSB-AGM 27M

## Nominal Technical Specifications

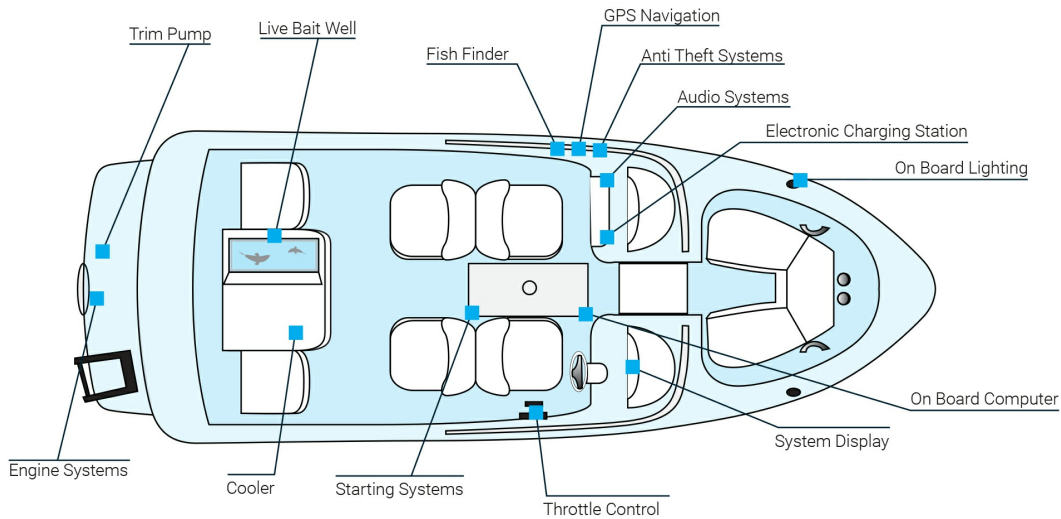

### Technical data

Terminal configuration	Marine/SAE
Terminal illustration	
Pulse cranking amps	1750 A
CCA rating at -18°C (0°F)	930 A
CA/MCA rating at 0°C (32°F)	1080 A
Reserve capacity	190 min
Capacity - 20 hour rate (1.75 vpc)	92 Ah
Internal resistance	2.6 mΩ @ 25°C (77°F)
Short circuit current	5000 A
Warranty	3 years full
Quantity per layer	15
Quantity per pallet	30

### Technical Drawing

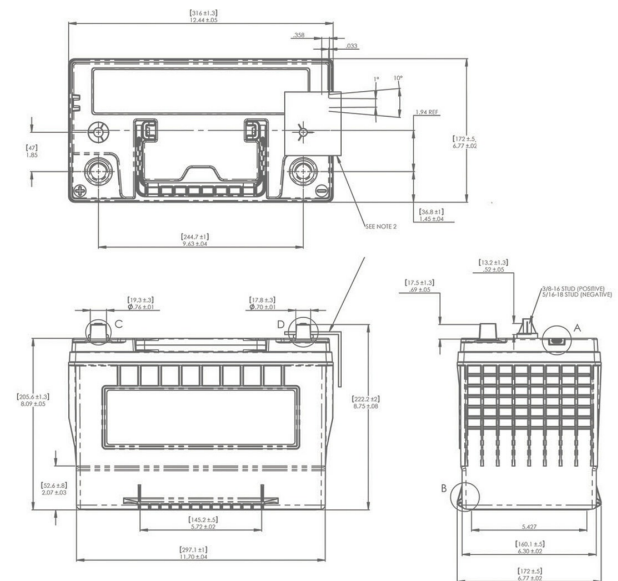

All NorthStar batteries are compliant with Battery Council International standards, UL approved and UN2800 certified. NorthStar is registered to ISO 9001 and ISO 14001.