



VISION Rechargeable Products Sealed Lead Acid Battery

www.vision-batt.com

UNA Series

High Rate Discharge

The new VISION UNA series batteries are specially designed for applications where need high power output. By optimum design of battery grids and plate paste formula, the UNA series can deliver up to 40% more power than VISION standard CP/FM series.

Shenzhen Center Power Tech Co., Ltd has more than 20 year's experience in the manufacturing of VRLA batteries.

SZCPT is one of the largest manufacturers of SLA (or VRLA) batteries in the world, the largest one in Mainland China and the first in China to develop and commercialize the sealed lead-acid battery with brand name VISION and has been at the forefront of battery technology from day one.

SZCPT leads the world in innovative battery technology. Our global network of sales and service engineers, backed in turn by our agents and distributors, means that we are currently active in more than 100 countries.

Shenzhen Center Power Tech. Co., Ltd

UNA12-320 12V 320W

(Edition 2014-9)

General Features

- Positive and negative plates in lead-calcium tinalloy
- Superior energy density
- Operates at a low internal pressure.
- Gas Recombination
- Usable in any orientation
- A recognized component of UL
- Very high power output
- Application specific designs
- A couple Range from 90W to 540W per cell for 15' @ 1.67Vpc
- Six months shelf life at 20°C
- Design life 10 years



Dimensions and Weight

	Metric Units	English Units
Length	258mm	10.2inch
Width	166mm	6.54inch
Height	210mm	8.27inch
Total Height	215mm	8.46inch
Approx. Weight	24.5Kg	54.0lbs

Performance Characteristics

- Nominal Voltage 12V
- Number of cell 6
- Nominal Capacity 77°F(25°C)
 - 15 min wattage @1.67V 320W/cell
 - 10 hour rate (7.50A, 10.8V) 75Ah
- Torque setting:8.5NM
- Internal Resistance
 - Fully Charged battery 77°F(25°C) ≤ 5.0mOhms
- Self-Discharge
 - 3% of capacity declined per month at 20°C(average)
- Operating Temperature Range
 - Discharge -20~60°C
 - Charge -10~60°C
 - Storage -20~60°C
- Max. Discharge Current 77°F(25°C) 700A(5s)
- Charge Methods: Constant Voltage Charge 77°F(25°C)
 - Cycle use 2.40-2.45VPC
 - Maximum charging current 22.5A
 - Temperature compensation -30mV/°C
- Standby use 2.20-2.30VPC
 - Temperature compensation -20mV/°C



Center Power Industrial Park, Tongfu Industrial District Dapeng Town, 518120 Shenzhen, China
Tel: 86 755 84318088 Fax: 86 755 84318038 E-mail: sales@vision-batt.com
Website: <http://www.vision-batt.com>

UNA12-320 12V 320W

Discharge Data

Constant Current Discharge Data (Ampere at 25 °C)									
End Voltage Volts/Cell		10min	15min	20min	30min	40min	45min	50min	60min
1.60		237	183	150	113	90.8	83.6	77.1	65.8
1.67		219	170	141	108	87.8	80.2	73.8	63.4
1.70		210	164	136	105	85.9	78.3	71.9	61.1
1.75		192	154	129	100	83.4	75.3	69.8	59.2
1.80		177	144	122	93.8	77.5	70.1	64.6	55.1

Constant Power Discharge Data (Watts at 25 °C)									
End Voltage Volts/Cell		10min	15min	20min	30min	40min	45min	50min	60min
1.60		422	327	270	203	162	150	139	118
1.67		397	320	259	197	160	147	135	116
1.70		385	301	253	194	158	145	133	113
1.75		358	288	243	187	152	143	128	110
1.80		330	273	233	179	147	135	124	106

(Note)The above characteristics data are average values obtained within three charge/discharge cycles not the minimum values.
All data shall be changed without notice, Vision reserves the right to explain and update the information contained hereinto.

Performance drawings

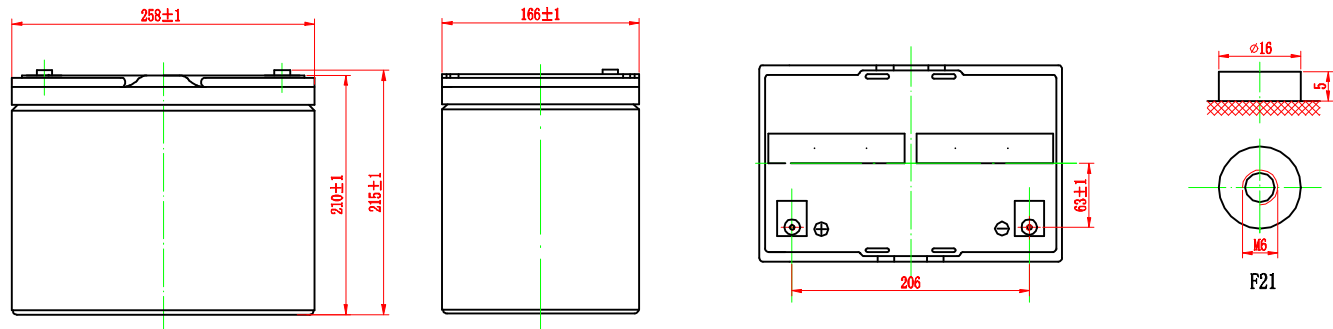

UNA12-320 12V 320W

